

VCL Carriage Ladder Fitting Instruction

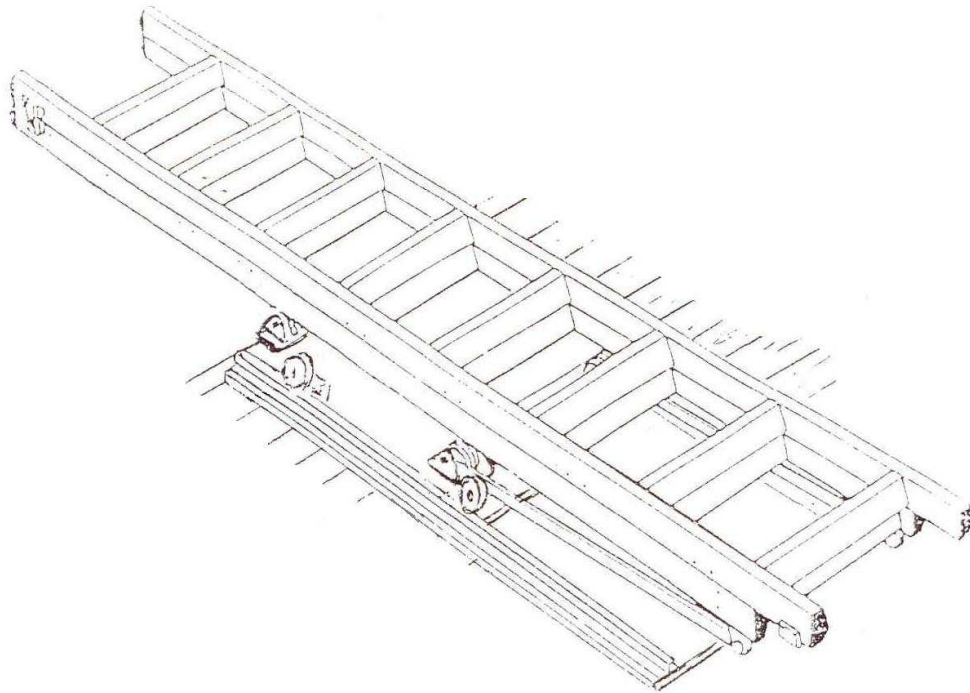

Assembly

Do not attempt to use this loft ladder until it has been properly installed and stages ① - ③ have been completed.

It is recommended that the installation is carried out by two people.

Read the instructions completely before attempting to install this loft ladder and make sure they are fully understood.

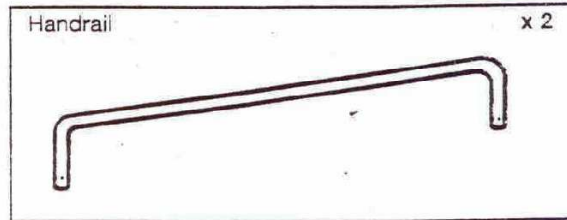
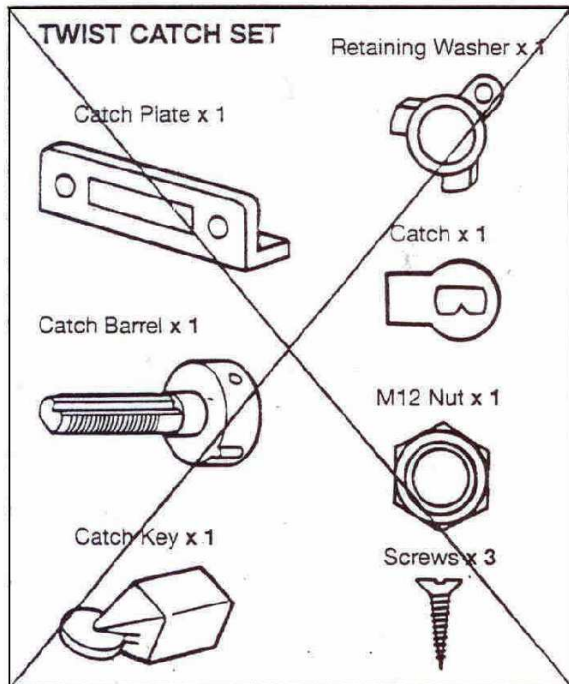
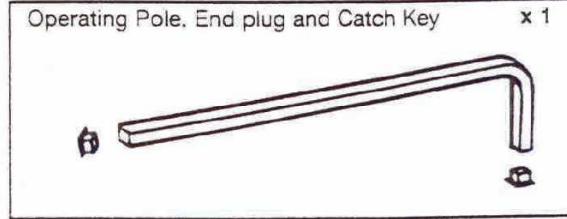
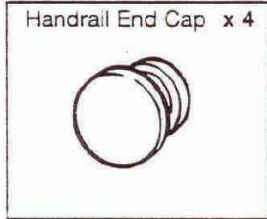
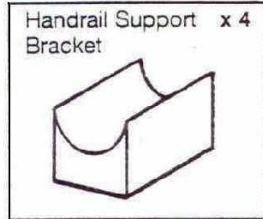
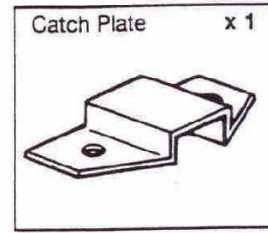
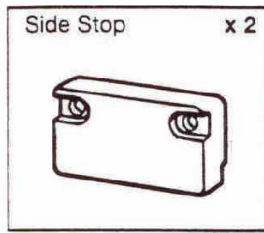
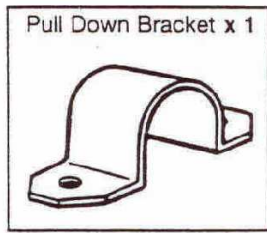
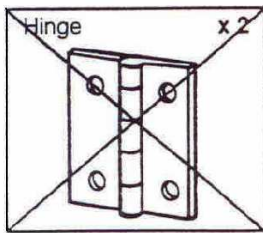

Tools Required

- Crosshead Screwdriver
- Flat Bladed Screwdriver
- Bradawl
- Spanners 8mm x 2 + 19mm
- Electric Drill + 2mm drill bit
- Tape Measure

Additional Fixings Supplied

- (G) 5mm x 40mm Goldscrew x 6
(To fix down spring board)
- (H) 5mm x 30mm Pan Head x 8
(to fix down hinge brackets)
- (I) 6mm x 15mm Pinhead x 2
(stops on main ladder)

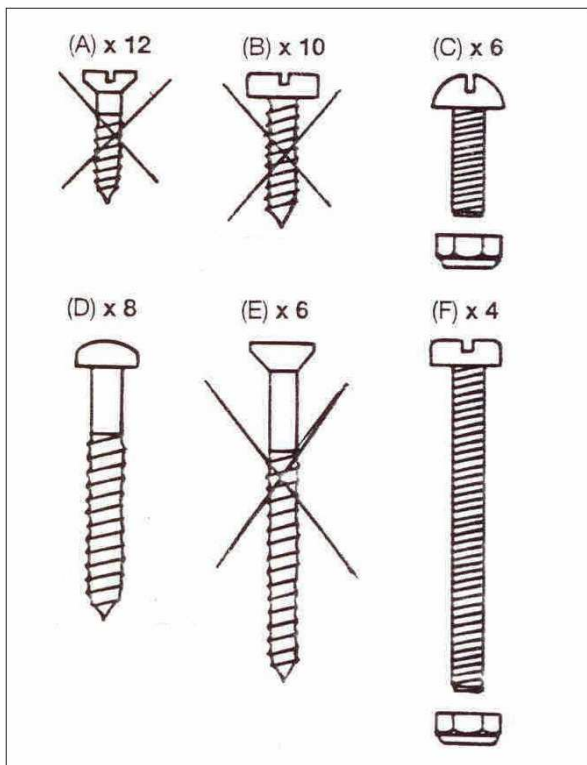

1. FIXING RUNNINGBOARD TO FLOOR

Fix baseboard to loft ladder using screws (D) through rails.
Front rails should be max 40mm from edge of loft floor

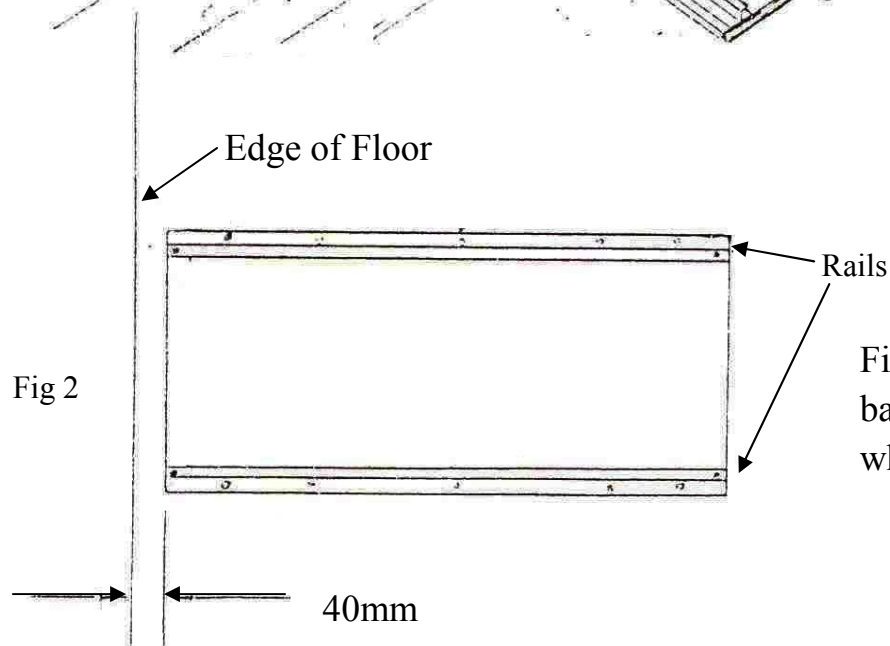
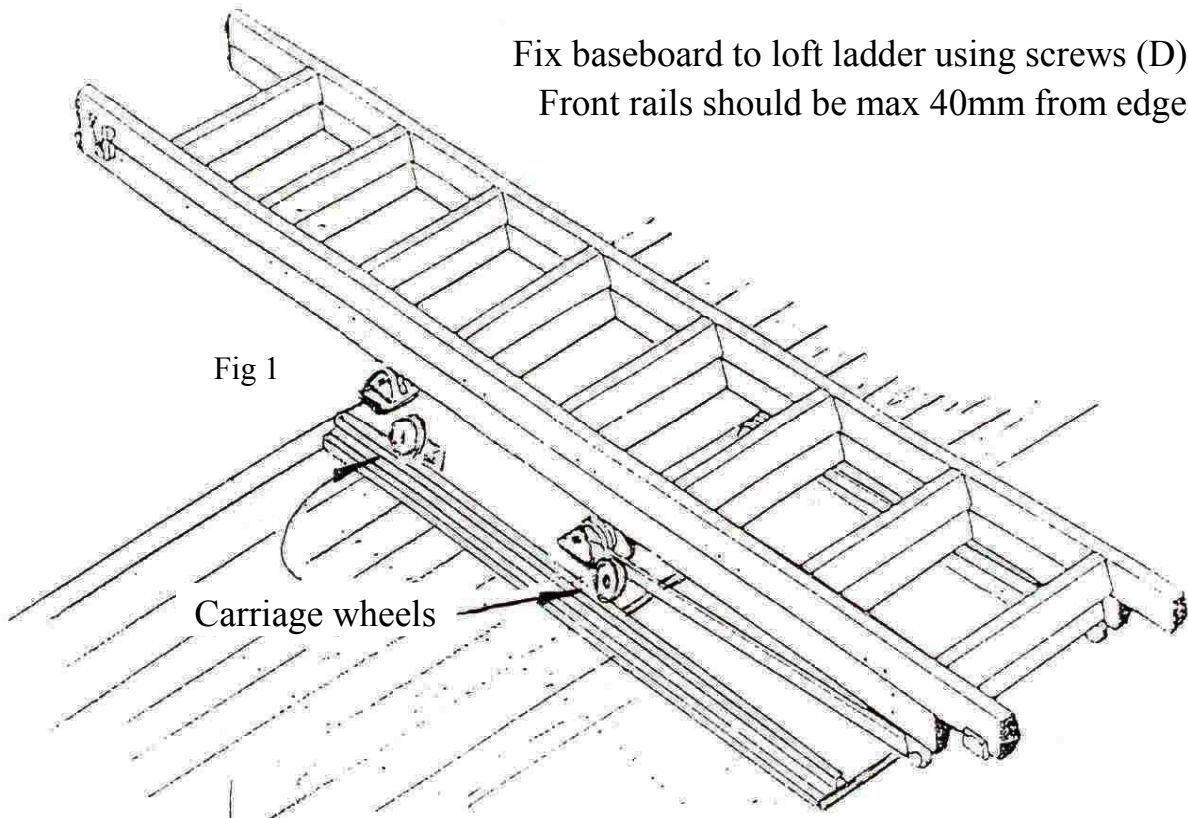
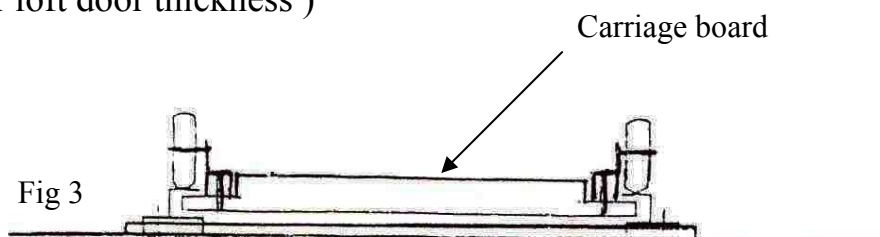

Fig. 2 For ease of use
base board must be flat
when fixed.

(Max space for loft door thickness)



2. FITTING SIDE STOP AND CATCH PLATE

Measure the floor to loft floor height. Refer to the table to determine the positions for the catch plate and side stops. Fit the catch plate and side stops as shown using 6 nuts and bolts (C). Ensure that the side stops are only projected slightly beyond the edge of the ladder.

Catch Plate Position	Side Stop Position	Floor to Floor Height Range
A	E	2270mm (7'5") - 2505mm (8'4")
B	F	2505mm (8'4") - 2740mm (9'0")
C	G	2740mm (9'0") - 2975mm (9'9")
D	H	2975mm (9'9") - 3210mm (10'6")

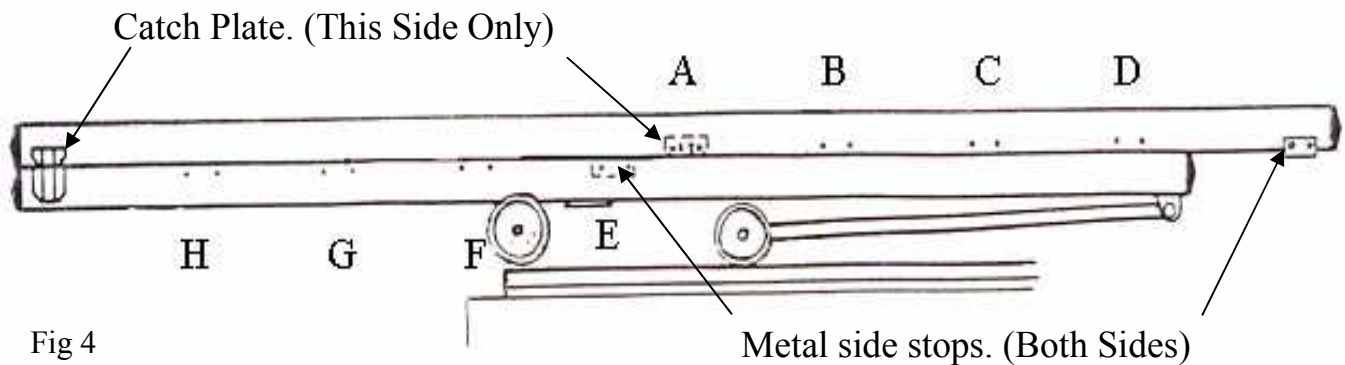
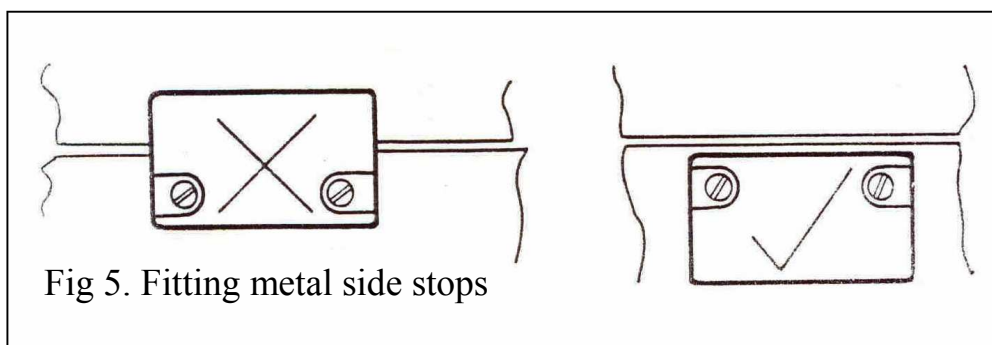

Fig 4

Slide ladder carefully to ground. (DO NOT STAND ON LADDER) . Align the treads on the ladder overlap. Fix the metal side stops as shown (fig. 5) in the appropriate holes for the height.

Fix catch plate. Fix upper stop. When adjusted correctly, the weight when the ladder is climbed is taken on the stops and not on the spring catch.



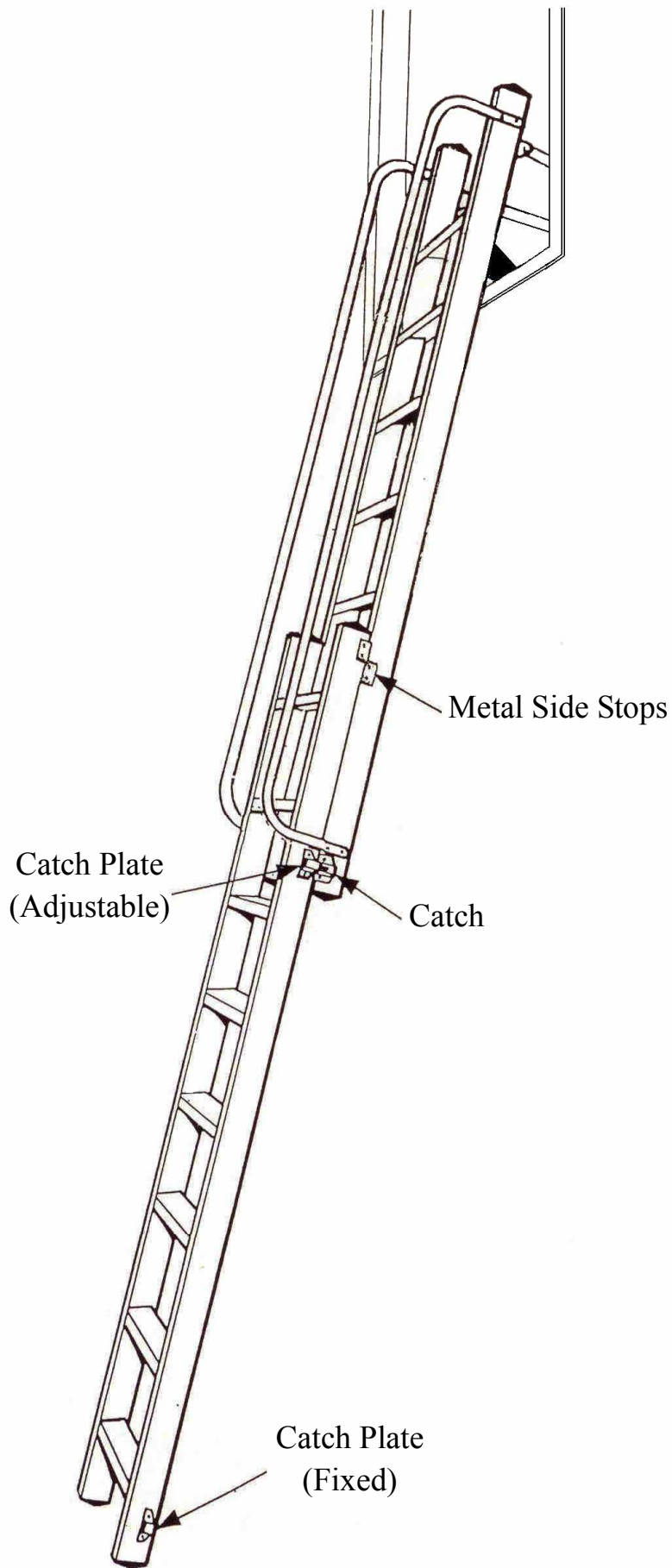
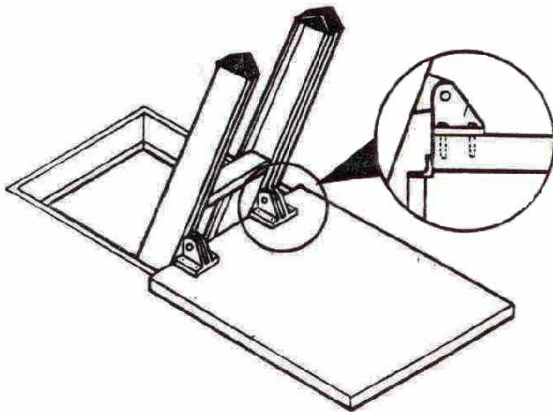

Fig 6

3. SECURING LADDER TO CARRIAGE BOARD.

Two people are recommended from this operation onwards - one in the loft and one on the landing. Gain access to the loft safely by using a suitable ladder.

Extend the loft ladder, engage the slide catch in the upper catch plate and lean it against the Running Board making sure it is centrally positioned. Remove and retain the nuts and bolts securing the adjusting stops in the channel on the rear edge of the upper section of the of the ladder.



Slide the upper hinge brackets up the channel and position on the Running Board so they are flush with the edge of the running board. Mark the hole positions and attach using the upper brackets to the board using 8 screws (H) provided.

Fig 7

Ensure the ladder is resting firmly on the landing floor at the appropriate angle with treads level to the floor (The ladder can be set slightly steeper or less steep at this stage if required).

Slide the adjustable stops down the channel in the rear edge of the upper section until they are resting on top of the upper hinge brackets. Using the nearest hole positions in the stops and ladder, refit and securely tighten the nuts and bolts that were previously removed. Count the hole positions carefully to ensure the stops are fitted at the same level

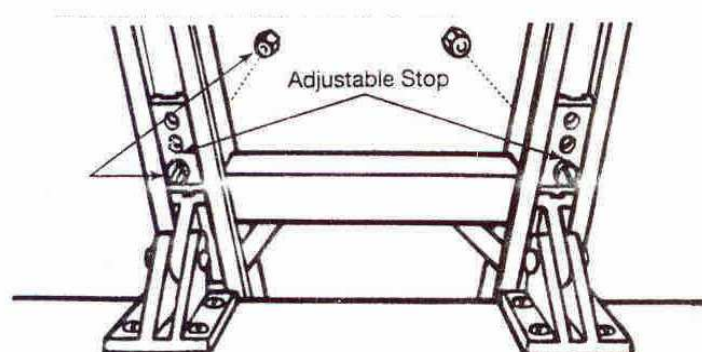

Fig 8

Disengage the springs from the pivot arms as shown in Fig (9). Lay the spring assembly on the running board, ensuring that it aligns with the centre of the ladder and parallel to the leading edge of the running board. (The guide on the running board gives only an approximate position for the spring assembly board). Fix the spring assembly to the running board using 6 screws (G) provided.

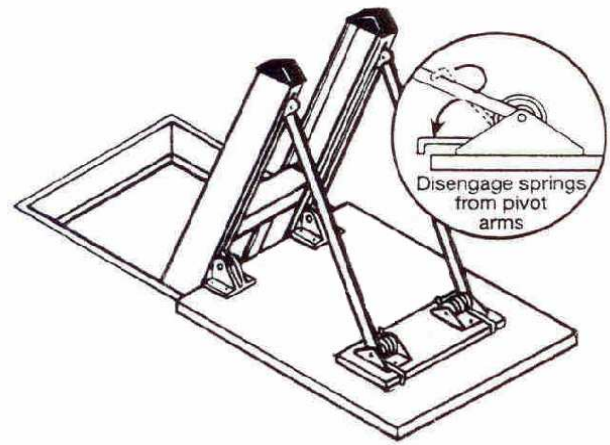

Fig 9

Re-engage the springs with the pivot arms as shown in the diagram below

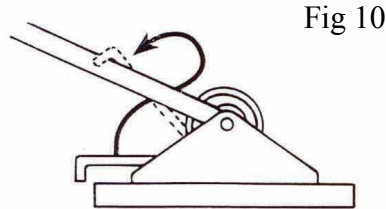

Fig 10

The ladder can now be safely used for access into the storage area to complete the installation.

4. One $\frac{1}{2}$ x No. 14 screw (I) is screwed into the small hole in the sliding black section on each side. These act as stops, so should be positioned and secured to prevent the ladder from laying horizontally in the stored position, whilst still allowing the bottom of the ladder to clear the base board when pushed away.

5. Fit the handrail using the 4 support plastic brackets using nuts and bolts (F) as shown in Fig 11

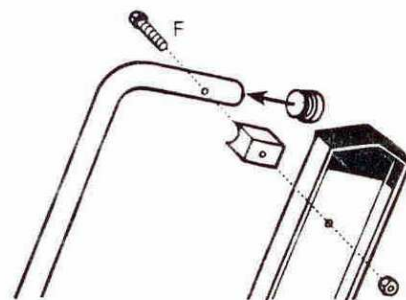
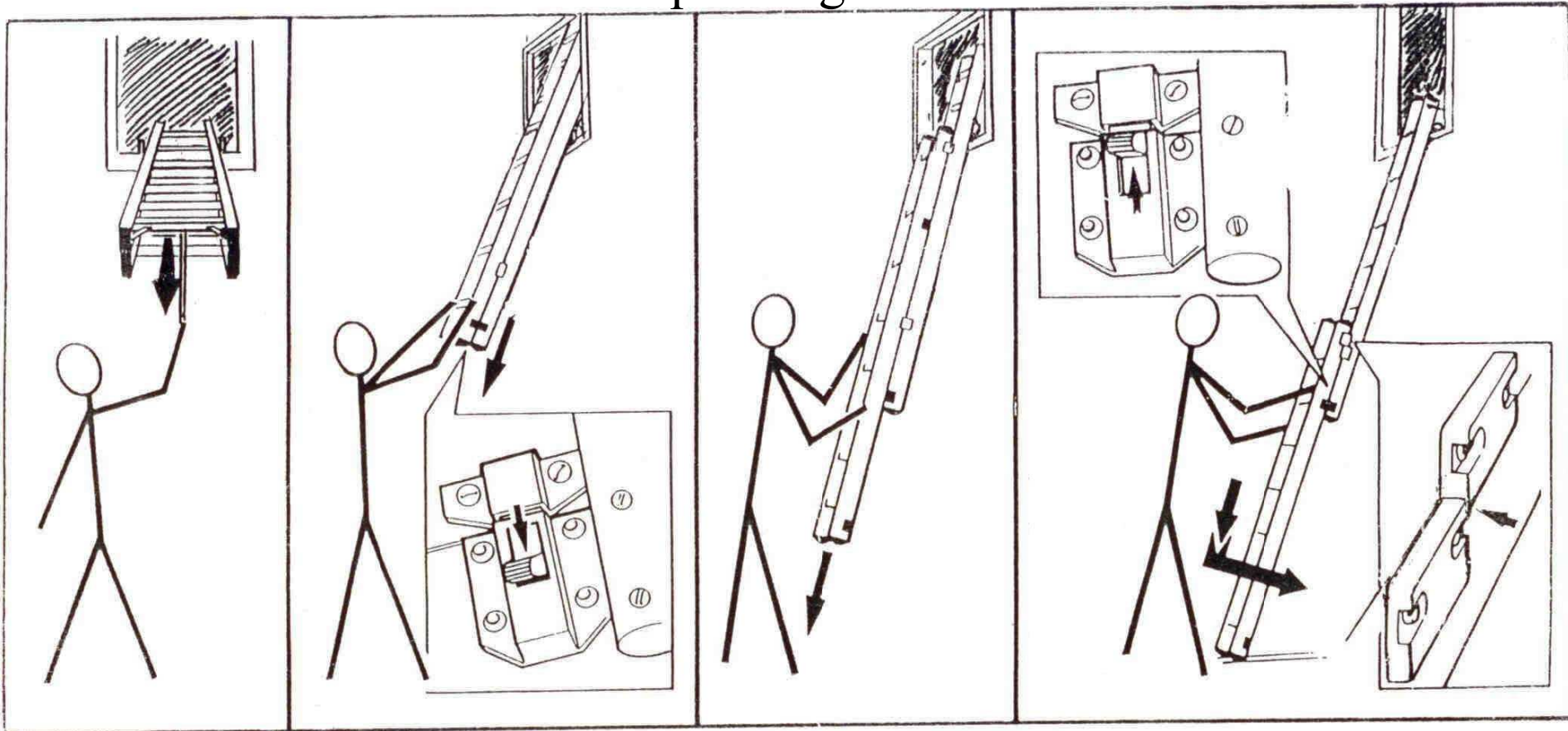

Fig 11

Operating Instructions



1. Pull ladder and carriage fully forward with pole

2. Pull ladder fully down with pole. Release catch and lower by hand

3. Extend to floor

4. Ensure catch is engaged in upper slot and ladder stops are abutted